

“DEMAND SIDE MANAGEMENT IN HYBRID SYSTEMS WITH HYDROGEN STORAGE IN SEVERAL DEMAND SCENARIOS IN ARAGON “

Rodolfo Dufo-López^a, José L. Bernal-Agustín^a, Luis Correas-Usón^b, Ismael Aso-Aguarta^b

^a Department of Electrical Engineering – University of Saragossa. Calle María de Luna, 3. E – 50018 Zaragoza (Spain) (rdufo@unizar.es)

^b Foundation for the Development of the New Hydrogen Technologies in Aragon. Walqa Technologic Park 22197 Huesca (Spain)(iaso@hidrogenoaragon.org)

ABSTRACT

This paper shows a study for the optimization of a PV-Wind-Diesel system with hydrogen storage located near Zaragoza (Saragossa) in Aragon, Spain. The study optimizes a renewable energy system with AC diesel generator and hydrogen storage with electrolyzer, hydrogen tank and fuel cell, to supply electric power to the loads. The design tool has been done with the HOGA program (Hybrid Optimizations by Genetic Algorithms). The objective function to minimize in the design process is the total Net Present Cost (NPC) of the system. The system is defined as a combination of components (PV generator, wind turbine, diesel generator, electrolyzer, hydrogen tank and fuel cell) and control variables. HOGA use genetic algorithms to find the optimal design of a hybrid system in low CPU time. In this paper several load profiles have been applied, comparing the results and showing the importance of the Demand Side Management.

1. INTRODUCTION

The mathematical design problem of sizing and control of the electrical generation hybrid systems involves a significant number of variables [1]. That is why classic design techniques are not able to obtain good results, being necessary to apply other techniques which allow obtaining satisfactory results. Heuristic techniques [2], such as Genetic Algorithms [3], can be more efficient than classical techniques, such as an Enumerative Technique, if the number of variables of the design problem is high. Genetic Algorithms present the advantage of having low computational requirements obtaining good solutions in reasonable time. The HOGA (Hybrid Optimization by Genetic Algorithms) program was introduced in previous works [4-8].

In this paper we describe the optimisation of a PV-Wind-Diesel system with hydrogen storage located near Saragossa in Aragon, Spain. Several load profiles have been used, comparing the results reached with each of them.

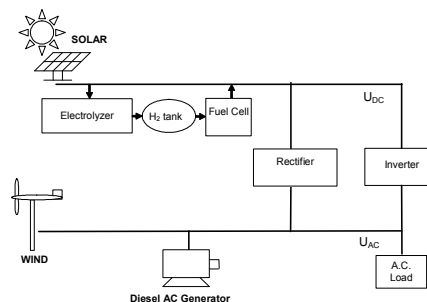

Fig. 1. Hybrid PV-Wind-Diesel-Hydrogen system

2. OPTIMIZATION BY GENETIC ALGORITHMS

The design program is made up of two Genetic Algorithms: the main one and the secondary one [5, 7, 8].

2.1 Main algorithm

This Genetic Algorithm searches for configurations of PV generator (type of PV panel and number in parallel), wind turbine (type of wind turbine and number in parallel), Diesel generator, fuel cell, electrolyser and inverter that minimize the Total Net Present Cost of the system (*NPC*). The codification is done through a vector that consists of 8 positions.

2.2 Secondary algorithm

This Genetic Algorithm obtains, for each configuration provided by the main algorithm, the control strategy that minimizes the *NPC*. HOGA can consider up to 12 control variables of the hybrid system. However, in this case (without batteries), only five variables are considered. The codification of the control variables [8] is done through a vector that consists of 5 positions:

$$| P_{\min_gen} | P_{\text{critical_gen}} | H2TANK_{\text{stp}} | P_{\min_FC} | P_{\text{lim_discharge}} |$$

P_{\min_gen} is the minimum power of the Diesel generator. It is generally set to the minimum value recommended by the manufacturer. Besides, the specific consumption (€/kWh) for low powers is always much higher than for high powers. This means that it may be possible that an optimal minimum power may exist with a higher value (as compared to the one recommended by the manufacturer) and below which the generator should not work, due to its high specific consumption. For the same reason, it may be interesting to produce more power even when it is required to generate a power under the critical power limit ($P_{\text{critical_gen}}$). That extra power could be used to produce H_2 in the electrolyzer to fill the H_2 tank up to the value named $H2TANK_{\text{stp}}$ (setpoint for the amount of H_2 stored in the tank, measured in kg). P_{\min_FC} is the minimum power of the Fuel Cell. The specific consumption (€/kWh) for low powers is always much higher than for high powers, so it may be possible that an optimal minimum power may exist with a higher value as compared to the one recommended by the manufacturer and below which the generator should not work, due to its high specific consumption. When the renewable sources are unable to provide all the energy demand, the load that has not been met should be produced either by the the AC Diesel generator or the fuel cell. For low power it is usually cheaper to supply with the generator, but for high power it can be the fuel cell. $P_{\text{lim_discharge}}$ is the limit. The design tool presented in this paper searches for the optimal value of all of these variables.

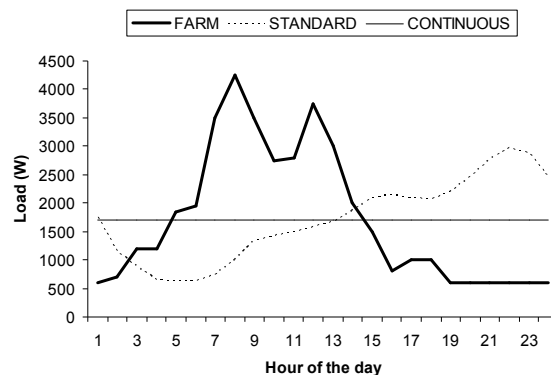

Fig. 2. Load profiles considered.

3. COMPUTATIONAL RESULTS

3.1. PV-Wind-Diesel-Hydrogen system.

The system is located near Zaragoza (Spain). The system has a 48 V DC voltage and a 230 V AC voltage. Only AC loads are present. Three different load profiles of the AC loads have been considered (Fig. 2). The maximum unmet load allowed is 1%. The system has a 48V DC voltage and a 230V AC voltage. The parameters of the genetic algorithms are the following (they are entered by the user): Main algorithm: Number of generations = 20, population = 200, crossover rate = 0.9, and mutation rate = 0.01. Secondary algorithm: Number of generations = 20, population = 50, crossover rate = 0.9, and mutation rate = 0.01. The average daily irradiation and average wind speed for every month is shown in Table 1.

Month	Jan.	Feb.	Mar.	Apr.	May	Jun.	July	Aug.	Sep.	Oct.	Nov.	Dec.
Average daily irradiation (kWh/m ²)	1,68	2,81	4,12	5,15	5,85	6,57	6,7	5,81	4,59	3,03	1,9	1,51
Average wind speed (m/s)	4,01	4,12	3,99	3,79	3,09	2,91	3,1	3,05	2,96	3,37	3,85	4,01

Table 1. Average monthly daily irradiation and wind speed.

There are 4 possible different PV panels, according to the power produced: 0, 50, 80 and 125 W, with prices 0, 387, 564 and 892 € respectively. The nominal voltage is 12 V. The lifespan is 25 years and the annual O&M cost is 40 €/year for the whole PV generator. The panels have an inclination of 60°, 0° azimuth and 0.2 albedo. Maximum number of panels in parallel is 40. There are 6 possible different DC wind turbines: 0, 275, 640, 1760, 3500 and 6500 W at 14 m/s, with prices 0, 2273, 3013, 4414, 6525 and 10018 € respectively. The estimated lifetime is 20 years and the annual O&M cost is about 50 €/year/wind generator. Maximum number of wind generators is 5, minimum is 1. In Fig. 3 the power curve of the 6500 W wind turbine is shown.

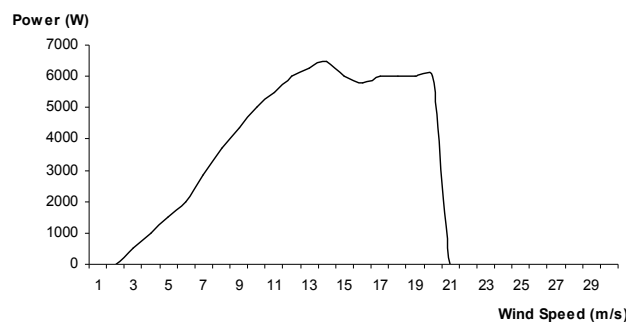

Fig. 3. Power curve of the 6500 W wind turbine.

There are 6 possible different Diesel generators: 0, 1.9, 3, 4, 5.5 and 7 kVA, with prices 0, 1269, 1514, 1900, 2314 and 2800 € respectively. The lifespan is 7000 h, the minimum output power is 30% and the hourly O&M cost ranges from 0.15 €/h to 0.24 €/h. The Diesel fuel consumption curve (l/h) is: $0.08415 \cdot P_{\text{rated}}(\text{kW}) + 0.246 \cdot P_{\text{output}}(\text{kW})$ [9].

There are 6 possible different fuel cells: 0, 1, 2, 3, 4 and 5 kW, with prices 0, 7000, 12000, 16000, 20000 and 24000 € respectively. The lifespan is 15000 h and the hourly O&M cost ranges from 0.1 to 0.2 €/h. The efficiency depends on the output power: the maximum efficiency is about 46% of the Hydrogen Lower Heating Value at 20% of the rated power; the efficiency for the rated power is

“17th World Hydrogen Energy Conference Brisbane June 2008 “

about 32%. There are 7 possible different electrolyzers: 0, 1, 2, 3, 4, 5 and 6 kW, with prices 0, 7200, 13500, 18000, 23000, 27000 and 31000 € respectively.

The lifespan is 10 years and the annual O&M cost ranges from 40 to 65 €/year. The efficiency depends on the output power, the maximum efficiency is 65% of the Hydrogen Higher Heating Value for the rated power. There are 5 possible different inverters: 0, 2.2, 3.3, 4.5 and 5.5 kVA, with prices 0, 2300, 3200, 4300 and 5200 € respectively. The lifespan is 10 years and the efficiency depends on the output power. The lifetime of the system considered is 25 years. The nominal interest rate considered is 4% annually and the annual general inflation is 2%. The fuel price is 1 €/l with 10% annual inflation. The cost of the hydrogen tank is 1,000 €/kg, with a lifetime of 25 years.

The cost of the rectifiers is (100 € + 200 €/kW), their lifetime is 10 years and their efficiency is 90%. The number of possible combinations of components is $(1+3*40)*(1+5*5)*6*6*7*5 = 3,963,960$.

	FARM LOAD PROFILE	STANDARD LOAD PROFILE	CONTINUOUS LOAD PROFILE
Peak power of PV generator (kW)	6.08 (19x4 panels of 80 W,12V)	6.08 (19x4 panels of 80 W,12V)	0
Power of the wind turbines (kW)	26 (4 Wind T. of 6500 W)	32.5 (5 Wind T. of 6500 W)	32.5 (5 Wind T. of 6500 W)
Rated output power of Diesel generator (kVA)	3	1.9	1.9
Rated output power of Fuel Cell (kW)	1	1	0
Rated output power of electrolyzer (kW)	1	1	0
Hydrogen tank capacity (kg)	8.34	1.75	0
Inverter nominal power (kVA)	5.5	5.5	3.3
Rectifier nominal power (kW)	0	1	0
Dispatch Strategy			
• P _{min_gen} (% of rated)	40 %	70 %	30 %
• P _{critical_gen} (W)	607 W	846 W	-
• H2TANK _{stp} (kg)	0 kg	1.75 kg	-
• P _{min_FC} (% of rated)	10%	10%	-
• P _{lim_discharge} (W)	1,214 W	0 W	-
• First at low discharge power	F.C.	Diesel	-
Unmet Load (%)	0 %	1 %	0 %
Annual Electrical Energy delivered by PV generator (kWh/yr)	4,928	4,928	0
Annual Electrical Energy delivered by Wind Turbines (kWh/yr)	30,162	37,703	37,703
Annual Electrical Energy delivered by Diesel generator (kWh/yr)	2,792	2,810	4,616
Annual Electrical Energy delivered by Fuel Cell (kWh/yr)	965	1,076	0
Annual Electrical Energy consumed by Electrolyzer (kWh/yr)	5,004	5,772	0
Annual Overall load Energy (kWh/yr)	14,947	14,947	14,947
Annual Excess energy (kWh/yr)	16,689	23,829	25,333
Diesel Gen. replacement cycle (yr)	4.5	3.9	2.05
Fuel Cell replacement cycle (yr)	9.6	9.2	-
Annual fuel cost (First year €/yr)	1,067	1,067	1,664
Total Net Present Cost of the system (€)	201,963	200,296	178,770

Table 2. Comparison between different load profiles. PV-Wind-Diesel-Hydrogen system

“17th World Hydrogen Energy Conference Brisbane June 2008 “

The secondary algorithm variables can have 8 values each (in steps of 14.3%). So the possible combinations of the control variables go up to $8^8 = 32,768$. The total number of combinations of components and control variables is $3,963,960 \times 32,768 = 1.2989 \times 10^{11}$. The number of cases evaluated by the main algorithm is $200 + 19 \times 200 \times (0.9 + 0.01 \times 8) = 3,924$ (0.099% of the possible combinations of components). The number of cases evaluated by the secondary algorithm is $50 + 19 \times 50 \times (0.9 + 0.01 \times 5) = 952$ (2.9% of the possible combinations of the control variables). The total number evaluated by the both algorithms is $3,924 \times 952 = 3,735,648$ (0.0029% of the total number of combinations of components and control variables).

The simulation time has been 16 h 25' for each load profile (63.2 combinations evaluated per second). The simulation time for all the combinations (not using Genetic Algorithms) would have been 65 years for each load profile. The configuration of the best combination of components and control variables found by the Genetic Algorithms for each load profile is shown in table 2.

The NPC of the best result found for the load profile “continuous” is about 10% lower than the best ones found for the other profiles. In this profile no hydrogen components are present.

The high wind speed in Zaragoza is the reason for the high power selected for the wind turbines in the best solution of each profile.

	FARM LOAD PROFILE	STANDAR LOAD PROFILE	CONTINUOUS LOAD PROFILE
Peak power of PV generator (kW)	16.64 (52x4 panels of 80 W,12V)	10.88 (34x4 panels of 80 W,12V)	8.32 (26x4 panels of 80 W,12V)
Rated output power of Diesel generator (kVA)	1.9	3	1.9
Rated output power of Fuel Cell (kW)	3	1	0
Rated output power of electrolyzer (kW)	1	1	0
Hydrogen tank capacity (kg)	7.227	0.136	0
Inverter nominal power (kVA)	5.5	3.3	3.3
Rectifier nominal power (kW)	1	0.165	0
Dispatch Strategy			
• P_{min_gen} (% of rated)	30 %	30 %	30 %
• $P_{critical_gen}$ (W)	607 W	0 W	-
• $H2TANK_{stp}$ (kg)	2.857 kg	0 kg	-
• P_{min_FC} (% of rated)	10%	10%	-
• $P_{lim_discharge}$ (W)	4,243 W	847 W	-
• First at low discharge power	Diesel	F.C.	-
Unmet Load (%)	0.9 %	0 %	0 %
Annual Electrical Energy delivered by PV generator (kWh/yr)	13,487	8,818	6,746
Annual Electrical Energy delivered by Diesel generator (kWh/yr)	7,720	9,849	10,375
Annual Electrical Energy delivered by Fuel Cell (kWh/yr)	763	301	0
Annual Electrical Energy consumed by Electrolyzer (kWh/yr)	3,446	1,588	0
Annual Overall load Energy (kWh/yr)	14,947	14,947	14,947
Annual Excess energy (kWh/yr)	1,578	1,290	1,268
Diesel Gen. replacement cycle (yr)	1.09	1.16	0.98
Fuel Cell replacement cycle (yr)	18	>25	-
Annual fuel cost (First year €/yr)	2,888	3,901	3,665
Total Net Present Cost of the system (€)	369,830	366,609	318,817

Table 3. Comparison between different load profiles. PV-Diesel-Hydrogen system

3.2. PV-Diesel-Hydrogen system.

The system studied in this section is the same as the shown in section 3.1 but without wind turbines and considering the maximum number of PV panels in parallel as 80. The configuration of the best combination of components and control variables found by the Genetic Algorithms for each load profile is shown in table 3.

In the PV-Diesel-Hydrogen system the *NPC* of the best result found for the load profile “continuous” is more than 10% lower than the best ones found for the other profiles, as happened in the cases with wind power included. In this profile no hydrogen components are present.

4. CONCLUSIONS

The conclusions determine that a in some cases, a good Demand Side Management can reduce the operation and installation costs of the hybrid systems, and that the load profile influences in the design of this type of systems.

Continuous load profiles have better *NPC* than others. HOGA software has been taken as reference tool of IEA HIA (Hydrogen Implementing Agreement) Subtask 18b “Integrated System Evaluations”. The software is freely downloadable at the website of the Foundation for Hydrogen in Aragón (<http://task18b.hidrogenoaragon.org/>)

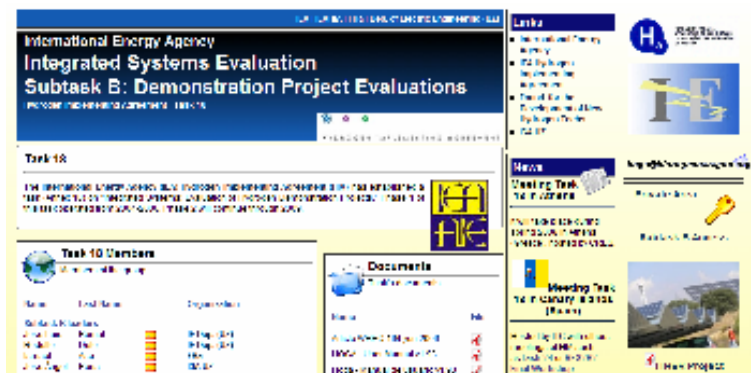

Table 4 – Web page Task 18 B “Integrated Systems Evaluation”

REFERENCES

1. Seeling-Hochmuth GC. A Combined Optimisation concept for the Design and Operation Strategy of Hybrid-PV Energy Systems. *Solar Energy* 1997; 61(2):77-87.
2. Bäck T, Fogel DB, Michalewicz Z. *Evolutionary Computation 1: Basic Algorithms and Operators*. Bristol and Philadelphia: Institute of Physics Publishing; 2000.
3. Goldberg, D.E. (1989). “Genetic Algorithms in optimization and Machine Learning”. (New York: Addison Wesley Publishing Inc., 1989).
4. Bernal-Agustín, J.L., Dufo-López, R., Rivas-Ascaso, D.M. (2006) “Design of Isolated Hybrid Systems Minimizing Costs and Pollutant Emissions”. *Renewable Energy* 31(14) pp. 2227-2244.
5. Dufo-López, R., Bernal-Agustín, J.L. (2005) “Design and control strategies of PV-Diesel systems using genetic algorithms”. *Solar Energy* 79(1), pp. 33-46.
6. Dufo-López, R., Bernal-Agustín, J.L., Contreras, J. (2006a) “Optimal Design of Hybrid Systems with Hydrogen Storage: Genetic Algorithms vs. Enumerative Methodology”. IX World Renewable Energy Congress, August 2006, Florence (Italy).
7. Dufo-López, R., Bernal-Agustín, J.L., Correas-Usón, L, Aso-Aguarta, I. (2006b) “Optimal Design of a Hydrogen Community by Genetic Algorithms”. 16th World Hydrogen Energy Conference (WHEC), June 2006, Lyon (France).
8. Dufo-López, R., Bernal-Agustín, J.L., Contreras, J. (2007) “Optimization of Control Strategies for Stand-Alone Renewable Energy Systems with Hydrogen Storage”. *Renewable Energy* 32 (7) pp. 1102-1126.
9. Skarstein, O., Ulhen, K. (1989) “Design Considerations with Respect to Long-Term Diesel Saving in Wind/Diesel Plants”, *Wind Engineering*, 13(2).